

4

3

2

1

B

B

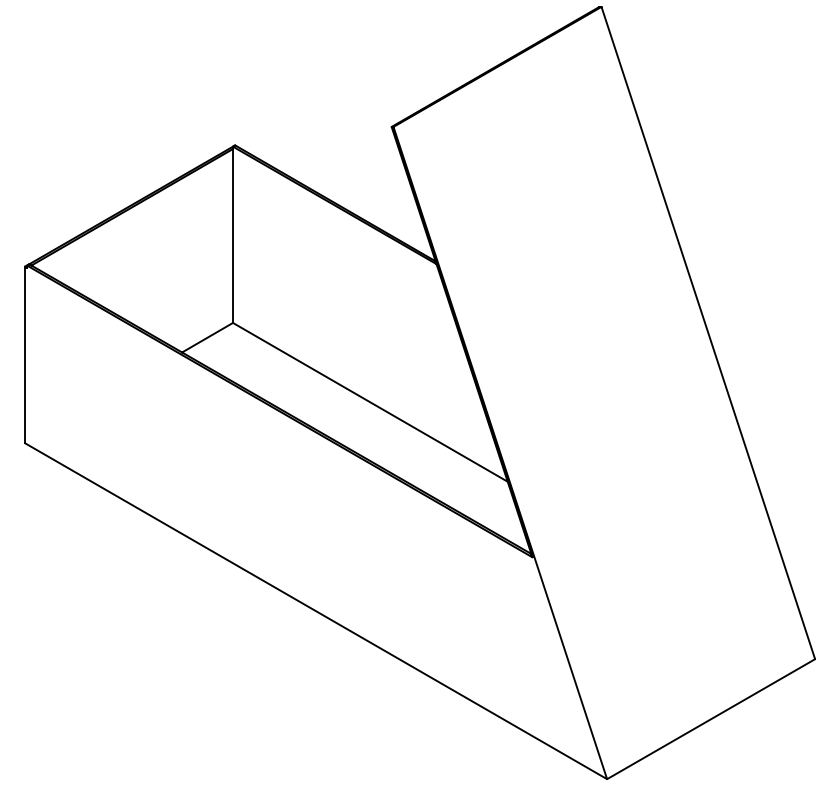
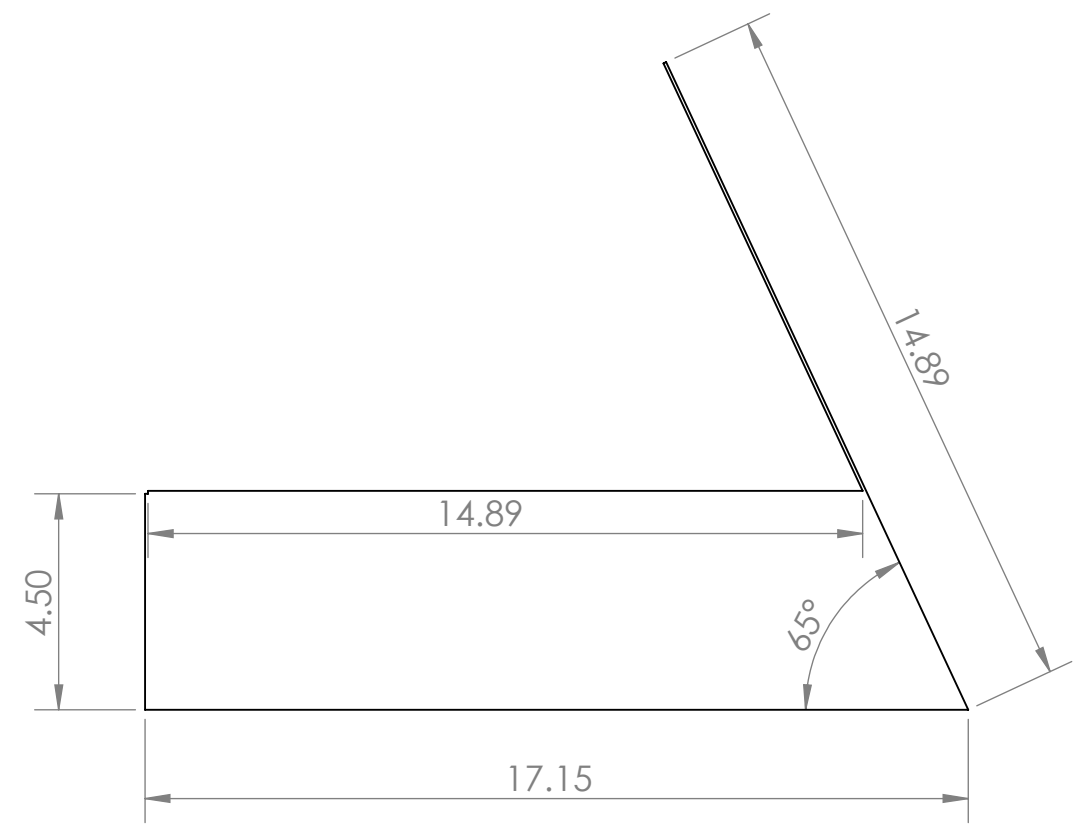
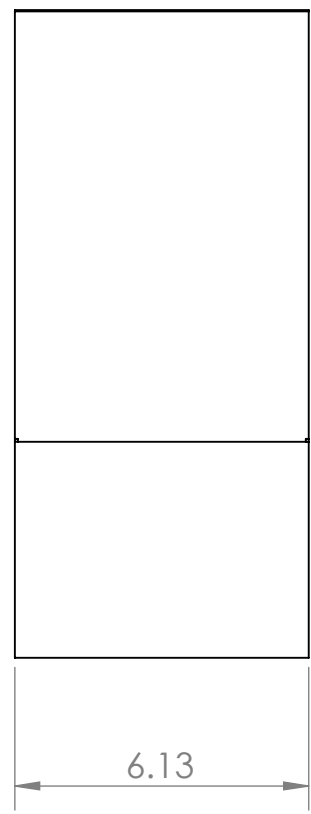

1/16" SHEET METAL IS USED TO MAKE THE COLLECTION BIN

A

A

PROPRIETARY AND CONFIDENTIAL
 THE INFORMATION CONTAINED IN THIS DRAWING IS THE SOLE PROPERTY OF <INSERT COMPANY NAME HERE>. ANY REPRODUCTION IN PART OR AS A WHOLE WITHOUT THE WRITTEN PERMISSION OF <INSERT COMPANY NAME HERE> IS PROHIBITED.

		UNLESS OTHERWISE SPECIFIED:		NAME	DATE	TITLE:
		DIMENSIONS ARE IN INCHES	DRAWN			
		TOLERANCES:	CHECKED			
		FRACTIONAL ±	ENG APPR.			
		ANGULAR: MACH ± BEND ±	MFG APPR.			
		TWO PLACE DECIMAL ±	Q.A.			SIZE DWG. NO. REV B collection bin
		THREE PLACE DECIMAL ±	COMMENTS:			
		INTERPRET GEOMETRIC TOLERANCING PER:				
		MATERIAL				SCALE: 1:4 WEIGHT:
		FINISH				SHEET 1 OF 1
NEXT ASSY	USED ON					
APPLICATION		DO NOT SCALE DRAWING				

4

3

2

1