

DEBUR AND BREAK SHARP EDGES	DO NOT SCALE DRAWING	REVISION
TITLE:	General Drawing	
MATERIAL:	DWG NO.	13
WEIGHT:	SCALE:1:5	SHEET 1 OF 5

Spectrometer drawing

The accuracy of the radius should be close.
Material should be 1/8" 6061

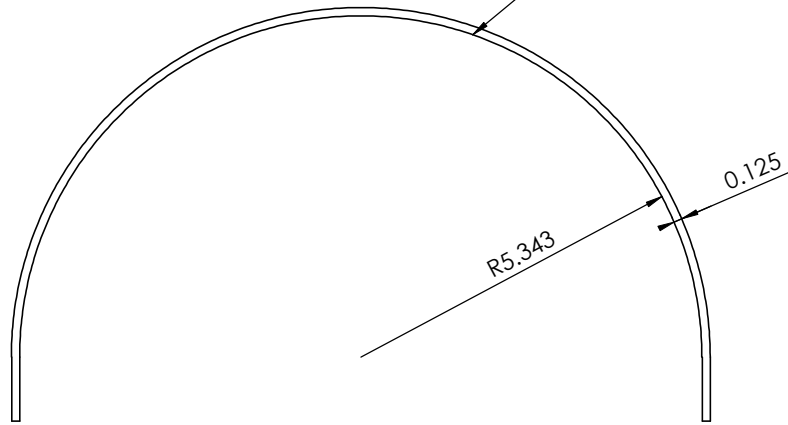

ShadowBand

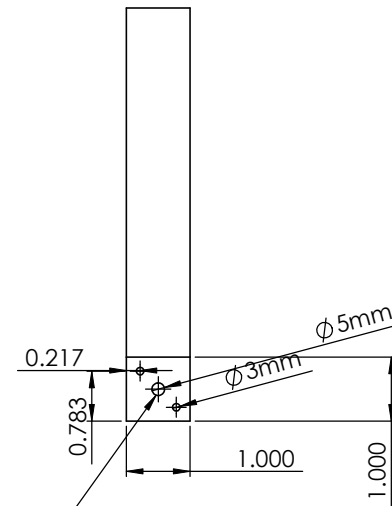

On one side include bushing
with 5mm ID inside hole

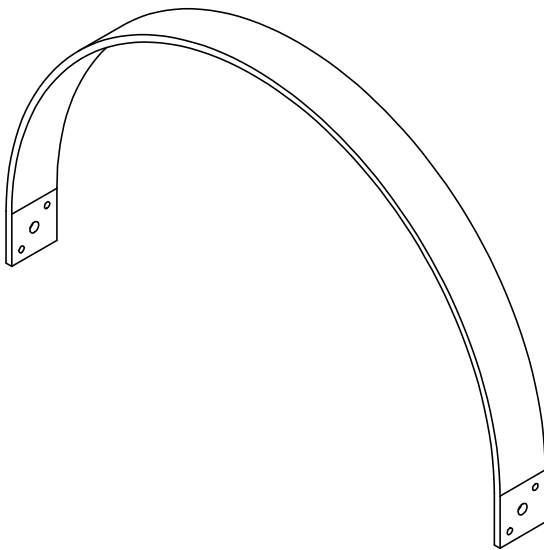

DEBUR AND BREAK SHARP EDGES	DO NOT SCALE DRAWING	REVISION
	Dr. Pearce	
TITLE:	shadowBand	
MATERIAL:	DWG NO.	DATE
WEIGHT:	SCALE:1:5	SHEET 2 OF 5

Spectrometer drawing

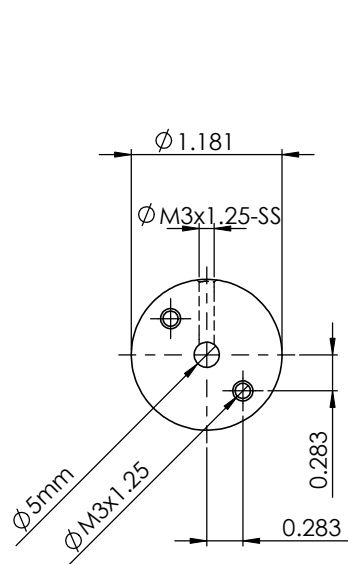

ShadowBand mounting hub

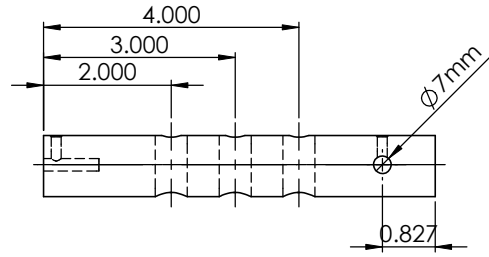
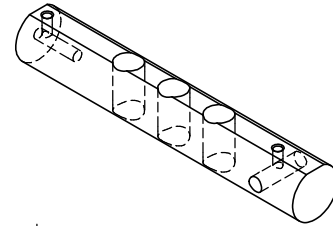
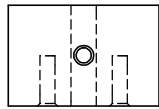
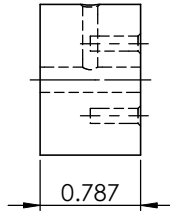
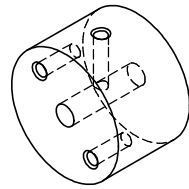

Flat to help with drilling holes. No particular dimensions

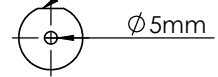

Fibre Optic cable mount hub

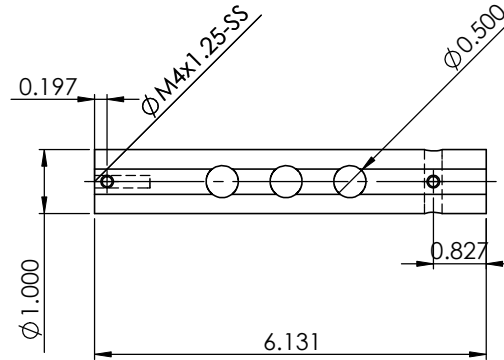

DEBUR AND BREAK SHARP EDGES	DO NOT SCALE DRAWING	REVISION
M.DeVuono	TITLE:	
MATERIAL:	DWG NO.	DATE:
	Spectrometer drawing	1/3
WEIGHT:	SCALE:1:5	SHEET 3 OF 5

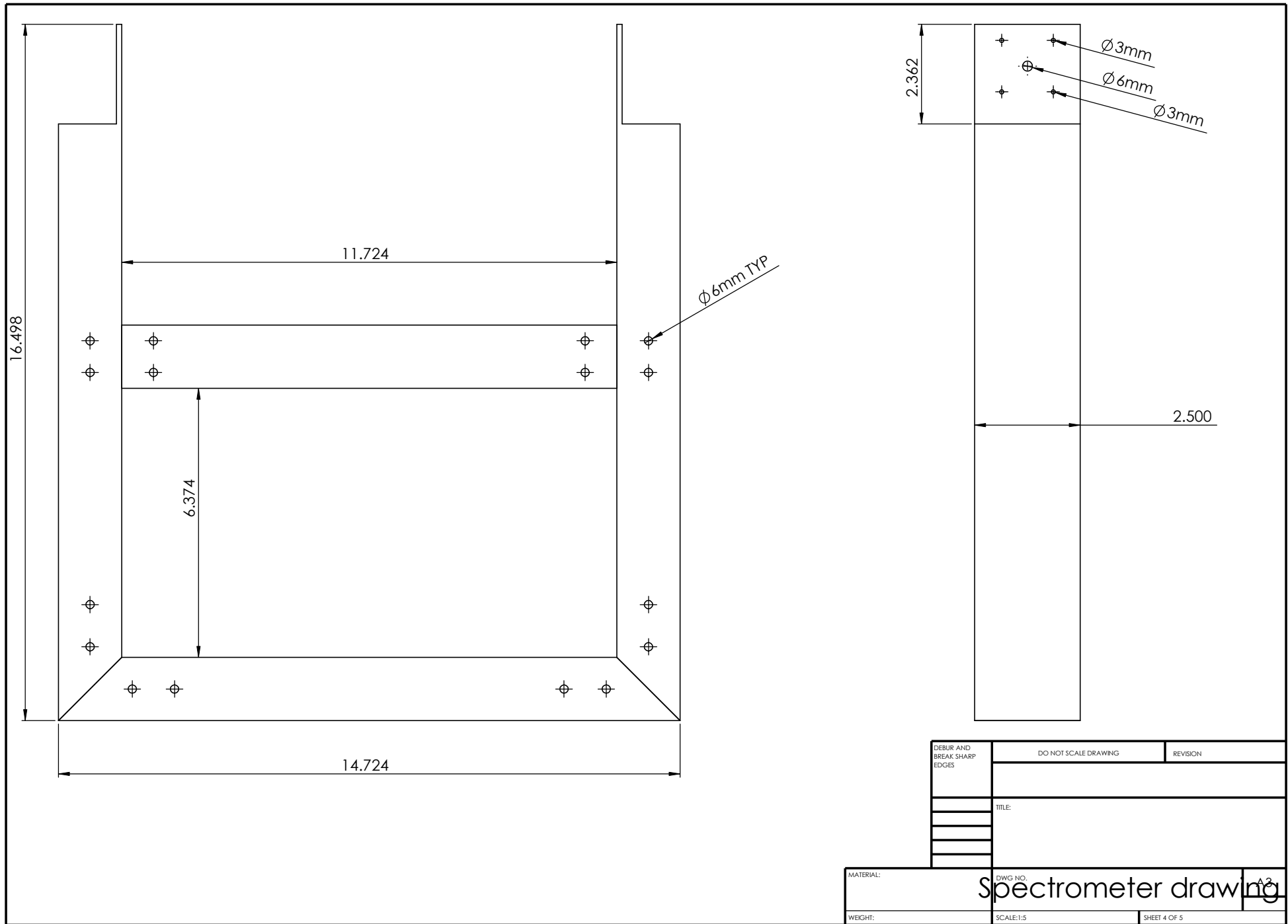

DEBUR AND BREAK SHARP EDGES	DO NOT SCALE DRAWING	REVISION
	TITLE:	
MATERIAL:	DWG NO.	13
WEIGHT:	SCALE:1:5	SHEET 4 OF 5

Spectrometer drawing

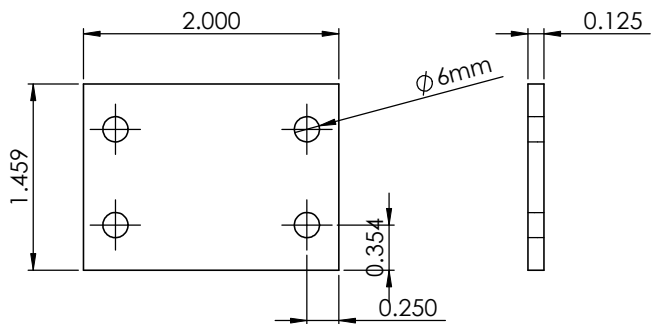

Frame brackets

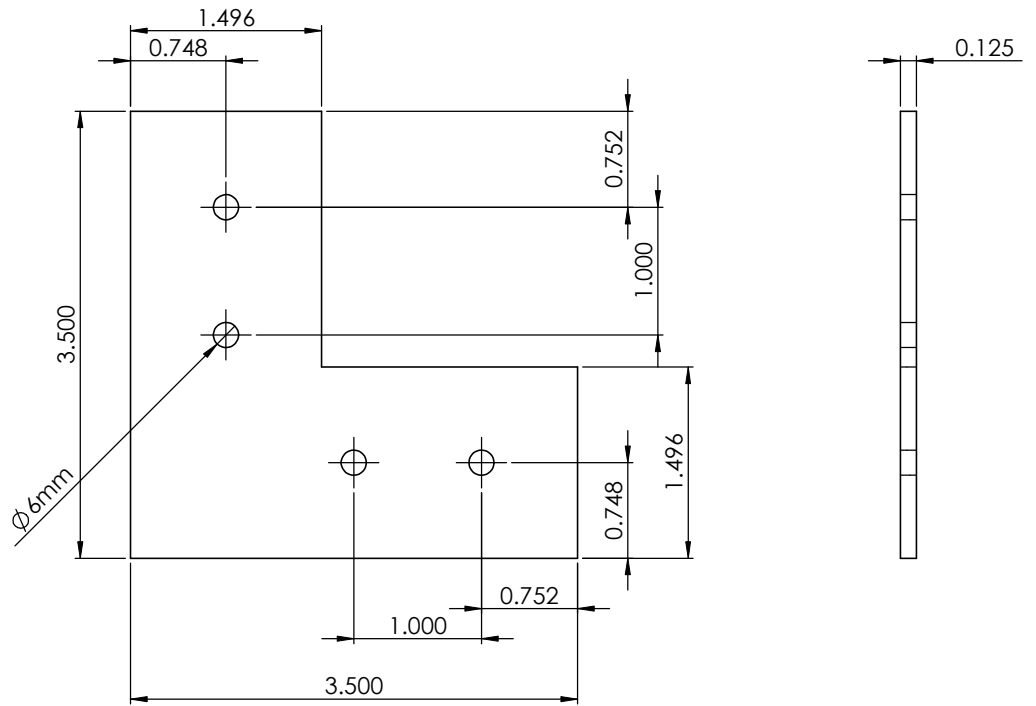

DEBUR AND BREAK SHARP EDGES	DO NOT SCALE DRAWING	REVISION
MATERIAL:	TITLE:	
	Spectrometer drawing	
WEIGHT:	DWG NO.	SHEET 5 OF 5
	SCALE:1:5	